

205 SERIES SMART CONTROLLER

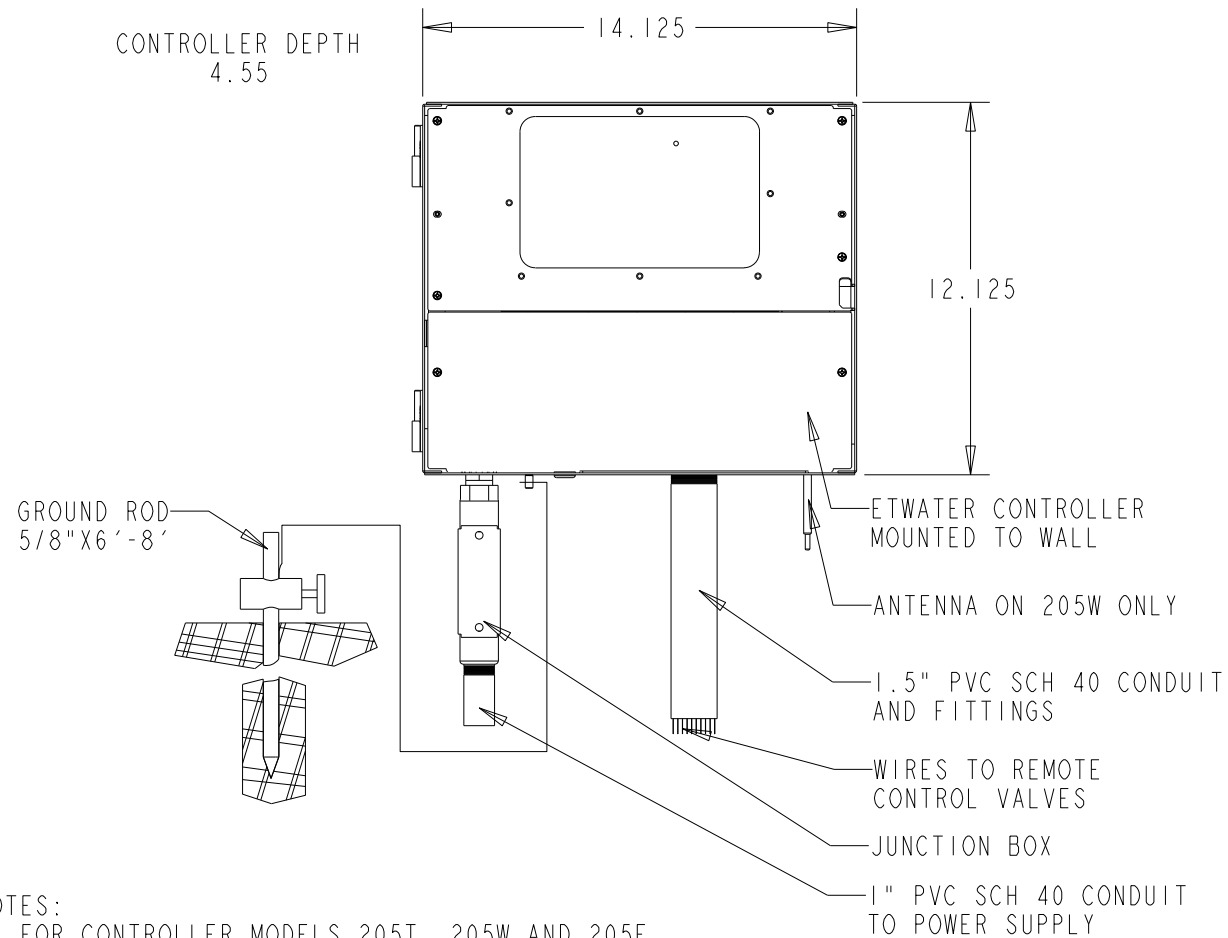

NOTES:

1. FOR CONTROLLER MODELS 205T, 205W AND 205F.
2. DO NOT SCALE DRAWING.
3. DOOR REMOVED FOR DRAWING CLARITY.
4. DIMENSIONS ARE IN INCHES.
5. INSTALLATION TO COMPLY WITH ALL NATIONAL AND LOCAL ELECTRICAL & BUILDING CODES.
6. POWER REQUIRED 110VAC @ 1.2 AMP OR LESS.